



**Bray**<sup>®</sup>

**SERIES 20/21 Wafer/Lug**  
**1"-20" (25mm-500mm)**

**BUTTERFLY VALVES**  
**SANITARY AND CHEMICAL / RESILIENT SEATED**



The  
High  
Performance  
Company

# SERIES 20

## 1"-20" (25mm-500mm)

Bray® Controls is proud to offer a high quality line of butterfly valves to meet the stringent requirements of today's applications. The Series 20/21 valve not only surpasses the high standards required in sanitary valve applications, but it also has unique inherent flow characteristics and capabilities. For High Performance in butterfly valve flow control, choose the "Engineer's Valve."

### DISC/STEM (A)

One-piece design. The disc edge is spherically machined and hand polished to produce a bubble-tight shut off, minimum torque, and longer seat life. The disc/stem is 316 Stainless Steel and PTFE or elastomer molded 316 Stainless Steel, and has a smooth finish free of porosity, voids and cracks. The disc/stem design inherently provides complete protection from particle entrapment and bacterial decay, protection that is required for sanitary performance. For superior erosion and abrasion resistance, the one-piece disc/stem is fully encased in either EPDM or Buna-N. These rubber-lined surfaces protect all metal surfaces from abrasive particles in the line media. The thin disc profile provides a much higher Cv (up to 50% greater than most through stem designs) and greater pressure recovery, thus resulting in lower pressure drops and a more energy-efficient valve. The disc/stem is available in a variety of standard materials to ensure maximum performance and service life to customers for their sanitary, corrosion, or erosion applications.

### STEM BUSHING (B)

Non-corrosive, heavy duty acetal bushing absorbs actuator side thrusts.

### STEM SEAL (C)

Double "U" cup seal design is self-adjusting and gives positive sealing in both directions. Prevents external substances from entering stem bore.

### NECK (D)

Extended neck length allows for 2" of piping insulation and is easily accessible for mounting actuators.



### BRAY UNIQUE SEAT DESIGN (E)

One of the valve's key elements is Bray's unique *tongue and groove* seat design. This resilient seat features lower torque than many valves on the market today and provides complete isolation of flowing media from the body.

The tongue-and-groove seat to body retention method is superior to traditional designs, making field replacement simple and fast. The seat is specifically designed to seal with slip-on or weld-neck flanges. The seat features a molded O-ring which

eliminates the use of flange gaskets. An important maintenance feature is that all resilient seats for Bray® butterfly valves Series 20, 21, 30, 31, and 34 are completely interchangeable.

### PRIMARY AND SECONDARY SEALS (F)

The Primary Seal is achieved by an interference fit of the unique molded seat flat with the disc hub. The secondary seal is created as a result of the stem diameter being greater than the diameter of the seat stem hole. These seals prevent line media from coming in contact with the stem or body.

### BODY (K)

Two-piece wafer or lug style allows for ease of assembly and maintenance. Nylon 11 coating for excellent corrosion resistance. All valve bodies meet ANSI 150 pressure ratings for hydrostatic shell test requirements.

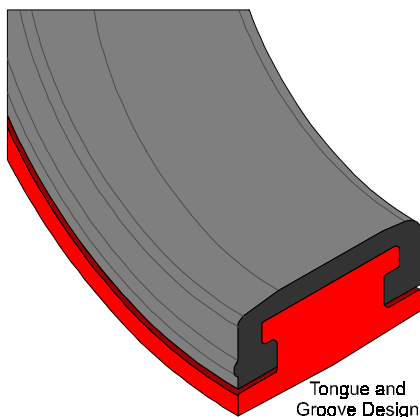



## BODY BOLTS (H)

Standard material is 316 Stainless Steel.

## ACTUATOR MOUNTING FLANGE AND STEM CONNECTION (I)

Universally designed to ISO 5211 for direct mounting of Bray® power actuators and manual operators.

## FLANGE LOCATING HOLES (J)

Provides quick and proper alignment during installation.

## DESIGN FEATURES

Bray's Series 20 valve is a wafer version with flange locating holes, and the Series 21 is the companion lug version for dead-end service and other flange requirements. All Bray valves are tested to 110% of full pressure rating before shipment. A major design advantage of Bray valve product lines is international compatibility. The same valve is compatible with most world standard flanges - ANSI Class 125/150, BS 10 Tables D and E, BS 4504 NP10/16, DIN ND10/16, AS 2129 and JIS 10. In addition, the valve is designed to be able to comply with ISO 5752 and ISO 5211. Therefore, one valve design is available for many different world markets. Bray interchangeability and compatibility offers you the best in uniformity of products and low-cost performance in the industry today.

Due to the modular concept of design, all Bray handles, manual gear operators, and pneumatic or electric actuators mount directly to Bray valves. No brackets or adapters are required.



For severe corrosive applications the one-piece disc/stem and seat are offered in PTFE with a standard Nylon 11 coated body. The basic seat design is PTFE bonded to EPDM and incorporates a unique primary/secondary sealing design. This PTFE valve provides excellent internal and external corrosion protection. Refer to Bray Technical Bulletin on PTFE, Nylon 11, and elastomer-covered Series 20/21 for further details and design features.

## NYLON 11 COATING CORROSION PROTECTION

Bray's standard product offers valve bodies 1"-8" (25mm-200mm) with a Nylon 11 coating, providing excellent corrosion and wear resistance to the valve's surface - the weakest part of most metal components. Nylon 11 is a thermoplastic produced from a vegetable base rather than a petroleum base. Nylon 11 advantages include:

- 1) Excellent Corrosion Resistance - Resists a broad range of chemical environments such as salt solutions, salt water, marine atmospheres, oils, greases and petroleum products. Salt spray tested in excess of 2,000 hours and seawater immersion tested for over 10 years without corrosion to metal substrates.
- 2) Abrasion Resistance - very low coefficient of friction, resulting in longer service life and increased performance.
- 3) sanitary Applications - inert to fungus growth and molds, highly stain resistant, USDA approved, as well as certified to ANSI/NSF 61 for water service.
- 4) Outdoor Weathering - resistant to ultraviolet radiation.
- 5) Impact Resistant - test have been performed without any peeling of coating.
- 6) Electrical properties - excellent dielectric properties.
- 7) Temperature Range -  
Max: continuous service +200°F (93°C),  
intermittent service up to +250°F (121°C).  
Min: -20°F (-29°C).

### DIMENSIONS SERIES 20 Wafer

Valve Size		Mtg Flange Drilling												
ins	mm	A	B	C	D	E	F	BC	No. Holes	Hole Dia.	G	H	J	K
1	25	2.36	1.18	1.25	1.73	3.54	2.56	1.97	4	.28	.39	.32	1.00	.44
1 1/2	40	3.16	1.26	1.84	2.53	4.12	2.56	1.97	4	.28	.39	.32	1.00	1.35
2	50	3.69	1.62	2.00	2.84	5.50	3.54	2.76	4	.39	.55	.39	1.25	1.32
2 1/2	65	4.19	1.75	2.50	3.34	6.00	3.54	2.76	4	.39	.55	.39	1.25	1.91
3	80	4.88	1.75	3.00	4.03	6.25	3.54	2.76	4	.39	.55	.39	1.25	2.55
4	100	6.06	2.00	4.00	5.16	7.00	3.54	2.76	4	.39	.63	.43	1.25	3.57
5	125	7.12	2.12	5.00	6.16	7.50	3.54	2.76	4	.39	.75	.51	1.25	4.63
6	150	8.12	2.12	5.75	7.02	8.00	3.54	2.76	4	.39	.75	.51	1.25	5.45
8	200	10.50	2.50	7.75	9.47	9.50	5.91	4.92	4	.57	.87	.63	1.25	7.45
10	250	12.75	2.50	9.75	11.47	10.75	5.91	4.92	4	.57	1.18	.87	2.00	9.53
12	300	14.88	3.00	11.75	13.47	12.25	5.91	4.92	4	.57	1.18	.87	2.00	11.47

### SERIES 21 Lug

Lug Bolting Data		
BC	No. Holes	Thrds UNC-2B
-	-	-
-	-	-
4.75	4	5/8-11
5.50	4	5/8-11
6.00	4	5/8-11
7.50	8	5/8-11
8.50	8	3/4-10
9.50	8	3/4-10
11.75	8	3/4-10
14.25	12	7/8-9
17.00	12	7/8-9

See Chart for Actuator Mounting Flange Drilling.

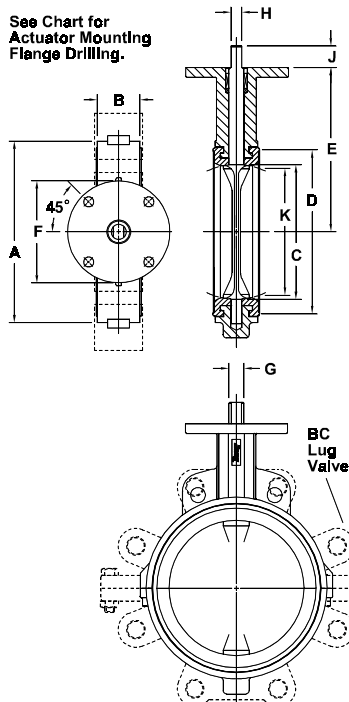

Valve Size		Mtg Flange Drilling												
ins	mm	A	B	C	D	E	F	BC	No. Holes	Hole Dia.	G	J	KEY SIZE	K
14	350	17.05	3.00	13.25	15.28	13.62	5.91	4.92	4	.57	1.38	2.00	.39x.39	13.04
16	400	19.21	4.00	15.25	17.41	14.75	5.91	4.92	4	.57	1.38	2.00	.39x.39	14.85
18	450	21.12	4.25	17.25	19.47	16.00	8.27	6.50	4	.81	1.97	2.50	.39x.47	16.85
20	500	23.25	5.00	19.25	21.59	17.25	8.27	6.50	4	.81	1.97	2.50	.39x.47	18.73

Lug Bolting Data		
BC	No. Holes	Thrds UNC-2B
18.75	12	1-8
21.25	16	1-8
22.75	16	1 1/8-7
25.00	20	1 1/8-7

# SELECTION DATA

## FLANGE REQUIREMENTS

Bray valves are designed for installation between ANSI 125/150 lb. weld-neck or slip-on flanges, BS 10 Tables D and E, BS 4504 NP10/16, DIN ND 10/16, AS 2129 and JIS 10, either flat faced or raised face. While weld-neck flanges are recommended, Bray has specifically designed its valve seat to work with slip-on flanges, thus eliminating common failures of other butterfly valve designs. When using raised face flanges be sure to properly align valve and flange. Type C stub-end flanges are not recommended.

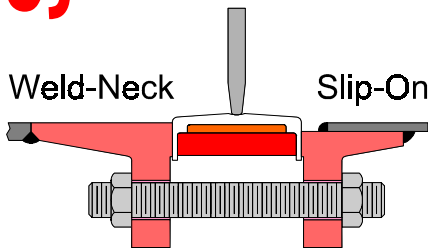

### PRESSURE RATINGS\*

When valve is placed between the flanges for bi-directional bubble-tight shut off, disc in closed position:

#### Disc/Stems for Resilient Seated Valves

316 Stainless Steel and Hastelloy® C:  
1"-20" (25mm-500mm) 150 psi (10 bar)  
EPDM and Buna-N Molded:  
2"-20" (50mm-500mm) 150 psi (10 bar)

#### Disc/Stems for PTFE Seated Valves

316 Stainless Steel and Hastelloy® C:  
2"-12" (50mm-300mm) 150 psi (10 bar)  
PTFE Molded:  
2"-12" (50mm-300mm) 100 psi (7 bar)

#### For Dead-end Service Applications

With *downstream flanges installed*, the dead-end pressure ratings are equal to valves bi-directional ratings as stated above. With no downstream flanges, the dead-end pressure rating for 2"-12" valves is 75 psi (5 bar) for 14"-20" valves, 50 psi (3.5 bar)

\* Pressure Ratings are based on standard disc diameters. For low pressure application, Bray offers a standard reduced disc diameter to decrease seating torque's and to extend seat life, thus increasing the valve's performance and reducing actuator coasts for the customer.

### VELOCITY LIMITS

For On/Off Services  
Fluids - 30 ft/sec (9m/s)  
Gases - 175 ft/sec (54m/s)

## Cv VALUES-VALVE SIZING COEFFICIENT

Valve Size		Disc Position (degrees)								
ins	mm	90°	80°	70°	60°	50°	40°	30°	20°	10°
1	25	61	56	36	21	11	5.6	2.7	.97	.07
1 1/2	40	147	129	87	50	26	12.8	5.9	1.7	.25
2	50	244	172	123	73	45	27	16	7	.89
2 1/2	65	439	310	201	115	71	43	25	11	1.4
3	80	691	488	290	165	102	62	35	16	2.0
4	100	1282	906	515	294	182	110	63	28	3.6
5	125	2070	1416	805	459	284	172	98	44	6
6	150	2786	1873	1065	607	376	227	130	59	7
8	200	5191	3402	1935	1147	714	427	244	106	13
10	250	8238	5385	3062	1815	1130	675	387	168	21
12	300	12102	7820	4448	2636	1642	981	562	245	31
14	350	15210	9829	5590	3313	2064	1234	706	307	40
16	400	19940	12885	7328	4343	2706	1617	925	403	52
18	450	26150	16898	9610	5695	3549	2121	1213	528	68
20	500	32690	21124	12014	7120	4436	2651	1517	660	85

Cv is defined as the volume of water in U.S.G.P.M. that will flow through a given restriction or valve opening with a pressure drop of one (1) p.s.i. at room temperature. Recommended control angles are between 25°-70° open. Preferred angle for control valve sizing is 60°-65° open.

## EXPECTED SEATING/UNSEATING TORQUE'S (Lb.-Ins.)

Valve Size		Full-Rated Pressure Valve				Reduced Disc Diameter
ins	mm	rP (PSI)				rP (PSI)
		50	100	150	175	50
1	25	65	71	77	80	65
1 1/2	40	95	100	106	110	95
2	50	125	130	135	140	125
2 1/2	65	195	205	215	220	195
3	80	260	275	290	297	260
4	100	400	425	450	462	267
5	125	615	670	725	755	410
6	150	783	871	953	1003	537
8	200	1475	1650	1825	1915	983
10	250	2240	2520	2800	2940	1493
12	300	3420	3870	4320	4545	2280
14	350	4950	5700	6450	-	3300
16	400	6400	7700	9000	-	4267
18	450	7850	9850	11850	-	5267
20	500	10300	12900	15500	-	6867

Valve Torque Rating - Bray has classified valve torque ratings according to 3 types: non-corrosive lubricating service, general service, and severe service. Consult Bray for torque information corresponding to specific application.

TO USE TORQUE CHART, NOTE THE FOLLOWING:

- 1) For Bray valves, Series 20, 21, 30, 31 and 34.
- 2) Review Technical Bulletin No. 1001, Expected Seating/Unseating Torque's, for explanation of the 3 service classes and their related seating/unseating torque values for given pressure differentials of Full-Rated and Reduced Disc Diameter valves.

- 3) Dynamic Torque values are not considered. See Technical Bulletin No. 1002 for evaluation of Dynamic Torque values vs. Seating/Unseating Torque values.
- 4) Do not apply a safety factor to above torque values when determining actuator output torque requirement.
- 5) For 3 way assemblies where on valve is opening and other is closing, multiply torque by 1.5 factor.

# SPECIFICATIONS

- Two-piece cast iron, wafer or lug bodies, Nylon 11 coated 1"-8", epoxy coated 10"-20".
- With flange locating holes that meet ANSI Class 125/150 (or BS 10 tables D and E, BS 4504 NP10/16, DIN ND 10/16, A 2129 and JIS 10) drillings.
- Disc/Stem of one-piece, high capacity design. If PTFE or rubber-covered disc/stem required, entire disc base material must be encapsulated and expose no part of stem or body to line media.
- Tongue-and-groove seat design with primary hub seal and a molded O-ring suitable for weld-neck and slip-on flanges. Seat totally encapsulates the body without flange gaskets.
- Spherically machined, hand polished disc edge and hub for minimum torque and maximum sealing capability.
- Equipped with non-corrosive bushing and self-adjusting stem seal.
- Bi-directional and tested to 110% of full rating.
- Bi-directional pressure ratings of 316SS, Hastelloy C disc/stem with resilient seat:
  - 1"-20" valves: 150 psi
  - EPDM or Buna-N molded disc/stem with resilient seat: 2"-20" valves: 150 psi
  - 316SS, Hastelloy C disc/stem, PTFE seat: 2"-12" valves: 150 psi
  - PTFE molded disc/stem with PTFE seat: 2"-12" valves: 100 psi
- Lug bodies for dead end service:
  - With downstream flanges or vulcanized seats, pressure ratings are equal to bi-directional ratings as stated above. With no downstream flanges or not vulcanized seats: 2"-12" valves : 50 psi
  - 14"-20" valves: 50 psi
- No field adjustment necessary to maintain optimum field performance.
- The valve shall be Bray® Series 20 wafer / 21 lug or equal.

## TEMPERATURE RANGE OF SEATS

Type	Maximum	Minimum
EPDM	+250°F(121°C)	-40°F(-40°C)
Buna-N	+212°F(100°C)	-0°F(-18°C)
FKM*	+400°F(204°C)	-0°F(-18°C)
PTFE-Lined EPDM	+250°F(121°C)	-20°F(-29°C)

\*FKM is the ASTM D1418 designation for Fluorinated Hydrocarbon Elastomers (also called Fluoroelastomers) such as Viton® (DuPont Dow Elastomers L.L.C.) and Fluorel® (3M).

## MATERIALS SELECTION

1"-20" (25mm-500mm)

### BODY:

- Cast Iron ASTM A126 Class B
- Ductile Iron ASTM A395
- 316 Stainless Steel ASTM A351 CF8m
- Aluminum ASTM B26 Class B

### SEAT:

- Buna-N - Food Grade
- EPDM - Food Grade
- FKM\*
- White Buna-N - Food Grade
- PTFE-Lined EPDM

### DISC/STEM:

#### All Metal

- 1"-12" One Piece (Investment Cast)
- 316SS per ASTM A351 Type CF8M
- Hastelloy® C-22 per ASTM b494 Type CX2MW
- 14"-20" (Fabricated)
- Disc EPDM 316SS per ASTM A240 Stem 316SS per ASTM A276
- Disc Hastelloy® C-276 ASTM B575 Alloy N10276 Stem Hastelloy® C-276 ASTM B575 Alloy N10276

#### Rubber Molded

- 2"-12" Material molded over One Piece S.S. insert (Investment Cast)
- EPDM - 17-4 ph SS per ASTM A747 Type CB7Cu-1 Heat Treated
- Buna-N - 17-4 ph SS per ASTM A747 Type CB7Cu-1 Heat Treated
- 14"-20" Material molded over S.S. insert (Fabricated)
- Disc EPDM - 316SS per ASTM A240 Stem EPDM - 17-4 ph SS per ASTM A564 Type 630 Heat Treated
- Disc Buna-N - 316SS per ASTM A240 Stem Buna-N - 17-4 ph SS per ASTM A564 Type 630 Heat Treated

#### PTFE Molded

- 2"-12" PTFE molded over One Piece S.S. insert (Investment Cast)
- 17-4 ph SS per ASTM A747 Type CB7Cu-1 Heat Treated
- 14"-20" PTFE molded over One Piece S.S. insert (Investment Cast)
- Disc 316SS per ASTM A240 Stem 17-4 ph SS per ASTM A564 Type 630 Heat Treated

#### Halar® Coated

- 2"-12" Halar® coated over One Piece S.S. insert (Investment Cast)
- 17-4 ph SS per ASTM A747 Type CB7Cu-1 Heat Treated
- 14"-20" Halar® coated over S.S. insert (Fabricated)
- Disc 316SS per ASTM A240 Stem 17-4 ph SS per ASTM A564 Type 630 Heat Treated

**Note:** not all materials are available in all valve sizes

Hastelloy® is a registered trademark of Haynes International, Inc. Halar® is a registered trademark of Ausimont U.S.A., Inc.

## WEIGHTS

Valve Size		Series 20	Series 21
ins	mm		
1	25	2.0	-
1 1/2	40	3.0	-
2	50	5.5	7.0
2 1/2	65	6.5	9.0
3	80	7.0	9.5
4	100	11.0	16.0
5	125	14.0	22.0
6	150	17.0	25.0
8	200	32.0	45.0
10	250	47.0	66.0
12	300	68.0	102.0
14	350	96.5	120.0
16	400	134.0	172.0
18	450	203.0	236.0
20	500	264.0	312.0

Weights are in lbs.

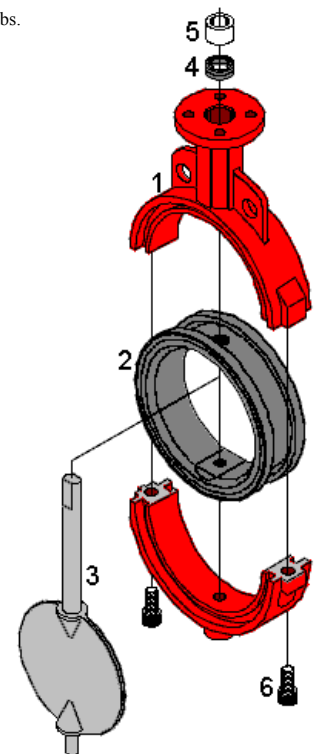

No.	Qty.	Description
1	1	Body
2	1	Seat
3	1	Disc/Stem
4	1	Stem Seal
5	1	Stem Bushing
6	2	Body Bolt

# ASSEMBLY

## INSTALLATION

Position the disc in the partially open position, maintaining the disc within body face-to-face. Place the body between flanges and install flange bolts. *Do not use flange gaskets.* Before tightening flange bolts, carefully open the disc to the full open position to ensure proper alignment and clearance of the disc O.D. with the adjacent pipe I.D. Leave disc in the full open position and tighten flange bolts per required specification. Once

bolts are tightened, carefully rotate disc to closed position to ensure disc O.D. clearance.

## MAINTENANCE AND REPAIR

The many Bray features minimize wear and maintenance requirements. No routine lubrication is required. All components—stem, disc, seat, bushing, stem seal, etc., are field replaceable, no adjustment is needed. If components require replacement, remove the valve from the line by placing the disc near the closed position, spread the flanges, support the valve, then remove the flange bolts. No valve maintenance, including removal of manual or power actuators, should be performed until the piping system is completely depressurized.

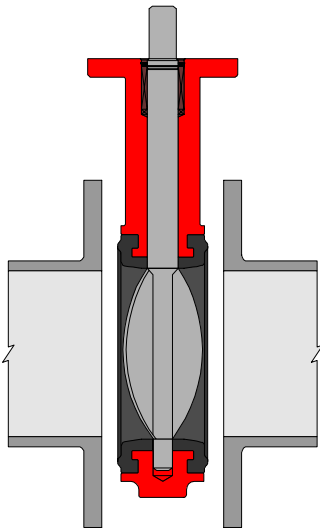

## DISASSEMBLY

Remove handle, manual gear box or actuator from actuator mounting flange. Remove the body bolts and pull the lower half away from the seat. Pull the seat and disc/stem from the upper body half. Remove bushing and seal from the upper body. Push the seat into an oval shape and remove the disc/stem by withdrawing the short stem end first.

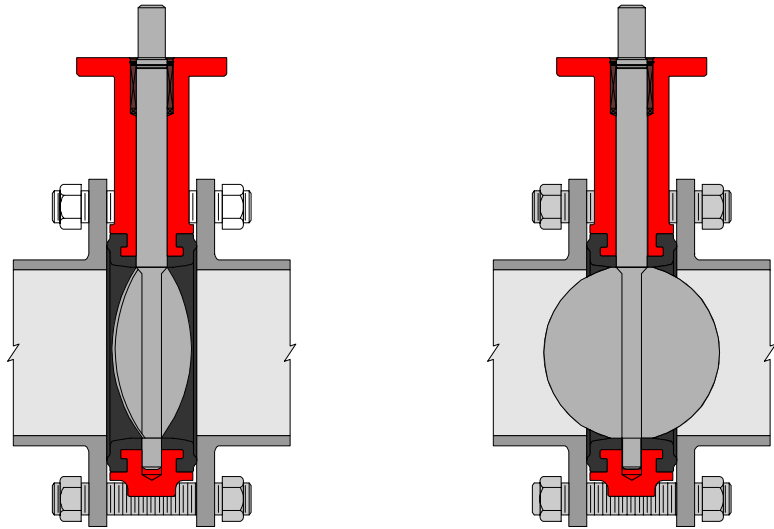

## ASSEMBLY

For aid in installing the disc/stem into the seat, install a light coat of silicone oil, food grade, onto the top and bottom stem and around the I.D. of the seat. (For silicone free applications use soap and water.) Push the long stem end of the disc/stem into the seat, then push the seat over the disc/stem short stem. Place the disc/stem and seat into the upper body half. Align the lower body bolt lugs with the upper body lugs and position lower body in the seat. Replace the body bolts and tighten. Install the stem seal, then the stem bushing. Replace handle, manual gear box or actuator on actuator mounting flange. Note: the body halves have a matching casting node on one side only to ensure correct assembly of body halves.

 **Bray** CONTROLS<sup>®</sup>

All statements, technical information, and recommendations in this bulletin are for general use only. Consult Bray representatives or factory for the specific requirements and material selection for your intended application. The right to change or modify product design or product without prior notice is reserved. Patents applied for in u.S. and foreign countries. Bray<sup>®</sup> is a registered trademark of BRAY INTERNATIONAL., Inc.

A Subsidiary of BRAY INTERNATIONAL, INC.  
13333 Westland East Blvd., Houston, Texas 77041  
Phone: 281.894.5454 Fax: 281.894.9499  
©1995 Bray International. All rights reserved